



Montacargas Eléctricos SERIE 7

3 y 4 llantas cushion

Capacidad de 1,500 a 2,000 kgs.

B16X/B18X/B20X-7
B15T/B18T/B20T-7



B15T-7

Tipo Mst	Max. Altura horquilla		Altura completamente bajada		Altura Completamente Extendida				Elevación Libre				Capacidades de carga nominal							
					Con respaldo de carga		Sin respaldo de carga		Con respaldo de carga		Sin respaldo de carga		Llanta Solida Simple				Llanta Cushion Simple			
					Ángulo inclin.		Cap. Carga		Ángulo inclin.		Cap. Carga		FWD	BWD	LC 24" (500mm)	FWD	BWD	LC 24" (500mm)		
					deg	deg	lb	kg	deg	deg	lb	kg								
STD	118.1	3,000	78.7	2,000	159.3	4,045	141.7	3,600	5.1	130	5.1	130	5	7	3000	1,500	5	7	3000	1,500
	129.9	3,300	84.6	2,150	171.1	4,345	153.5	3,900	5.1	130	5.1	130	5	7	3000	1,500	5	7	3000	1,500
	137.8	3,500	88.6	2,250	178.9	4,545	161.4	4,100	5.1	130	5.1	130	5	7	3000	1,500	5	7	3000	1,500
	145.7	3,700	92.5	2,350	186.8	4,745	169.3	4,300	5.1	130	5.1	130	5	7	3000	1,500	5	7	3000	1,500
	157.5	4,000	100.4	2,550	198.6	5,045	181.1	4,600	5.1	130	5.1	130	5	7	3000	1,500	5	7	3000	1,500
	177.2	4,500	110.2	2,800	218.3	5,545	200.8	5,100	5.1	130	5.1	130	5	7	2850	1,425	5	7	2900	1,450
FF	106.3	2,700	72.8	1,850	147.4	3,745	130.9	3,325	33.3	845	49.8	1,265	5	5	3000	1,500	5	5	3000	1,500
	118.1	3,000	78.7	2,000	159.3	4,045	142.7	3,625	39.2	995	55.7	1,415	5	5	3000	1,500	5	5	3000	1,500
	129.9	3,300	84.6	2,150	171.1	4,345	154.5	3,925	45.1	1,145	61.6	1,565	5	5	3000	1,500	5	5	3000	1,500
FFT	157.5	4,000	74.0	1,880	198.8	5,050	182.3	4,630	34.4	875	51.0	1,295	5	5	2900	1,450	5	5	2950	1,475
	177.2	4,500	80.5	2,045	218.3	5,545	201.8	5,125	40.9	1,040	57.5	1,460	5	5	2800	1,400	5	5	2850	1,425
	187.0	4,750	83.9	2,130	228.1	5,795	211.6	5,375	44.3	1,125	60.8	1,545	5	5	2700	1,350	5	5	2750	1,375
	196.9	5,000	88.4	2,245	238.0	6,045	221.5	5,625	48.8	1,240	65.4	1,660	5	5	2600	1,300	5	5	2700	1,350
	216.5	5,500	97.6	2,480	257.9	6,550	241.3	6,130	58.1	1,475	74.6	1,895	5	5	1950	975	5	5	2550	1,275
	236.2	6,000	104.1	2,645	277.4	7,045	260.8	6,625	64.6	1,640	81.1	2,060	5	5	1300	650	5	5	2450	1,225

B18T-7, B18TL-7

Tipo Mst	Max. Altura horquilla		Altura completamente bajada		Altura Completamente Extendida				Elevación Libre				Capacidades de carga nominal							
					Con respaldo de carga		Sin respaldo de carga		Con respaldo de carga		Sin respaldo de carga		Llanta Solida Simple				Llanta Cushion Simple			
					Ángulo inclin.		Cap. Carga		Ángulo inclin.		Cap. Carga		FWD	BWD	LC 24" (500mm)	FWD	BWD	LC 24" (500mm)		
					deg	deg	lb	kg	deg	deg	lb	kg								
STD	118.1	3,000	78.7	2,000	159.3	4,045	141.7	3,600	5.1	130	5.1	130	5	7	3500	1,750	5	7	3500	1,750
	129.9	3,300	84.6	2,150	171.1	4,345	153.5	3,900	5.1	130	5.1	130	5	7	3500	1,750	5	7	3500	1,750
	137.8	3,500	88.6	2,250	178.9	4,545	161.4	4,100	5.1	130	5.1	130	5	7	3500	1,750	5	7	3500	1,750
	145.7	3,700	92.5	2,350	186.8	4,745	169.3	4,300	5.1	130	5.1	130	5	7	3500	1,750	5	7	3500	1,750
	157.5	4,000	100.4	2,550	198.6	5,045	181.1	4,600	5.1	130	5.1	130	5	7	3500	1,750	5	7	3500	1,750
	177.2	4,500	110.2	2,800	218.3	5,545	200.8	5,100	5.1	130	5.1	130	5	7	3300	1,650	5	7	3300	1,650
FF	106.3	2,700	72.8	1,850	147.4	3,745	130.9	3,325	33.3	845	49.8	1,265	5	5	3500	1,750	5	5	3500	1,750
	118.1	3,000	78.7	2,000	159.3	4,045	142.7	3,625	39.2	995	55.7	1,415	5	5	3500	1,750	5	5	3500	1,750
	129.9	3,300	84.6	2,150	171.1	4,345	154.5	3,925	45.1	1,145	61.6	1,565	5	5	3500	1,750	5	5	3500	1,750
FFT	157.5	4,000	74.0	1,880	198.8	5,050	182.3	4,630	34.4	875	51.0	1,295	5	5	3350	1,675	5	5	3400	1,700
	177.2	4,500	80.5	2,045	218.3	5,545	201.8	5,125	40.9	1,040	57.5	1,460	5	5	3200	1,600	5	5	3300	1,650
	187.0	4,750	83.9	2,130	228.1	5,795	211.6	5,375	44.3	1,125	60.8	1,545	5	5	3050	1,525	5	5	3250	1,625
	196.9	5,000	88.4	2,245	238.0	6,045	221.5	5,625	48.8	1,240	65.4	1,660	5	5	2800	1,400	5	5	3150	1,575
	216.5	5,500	97.6	2,480	257.9	6,550	241.3	6,130	58.1	1,475	74.6	1,895	5	5	2050	1,025	5	5	3000	1,500
	236.2	6,000	104.1	2,645	277.4	7,045	260.8	6,625	64.6	1,640	81.1	2,060	5	5	1400	700	5	5	2800	1,400

B20T-7, B20TL-7

Tipo Mst	Max. Altura horquilla		Altura completamente bajada		Altura Completamente Extendida				Elevación Libre				Capacidades de carga nominal							
					Con respaldo de carga		Sin respaldo de carga		Con respaldo de carga		Sin respaldo de carga		Llanta Solida Simple				Llanta Cushion Simple			
					Ángulo inclin.		Cap. Carga		Ángulo inclin.		Cap. Carga		FWD	BWD	LC 24" (500mm)	FWD	BWD	LC 24" (500mm)		
					deg	deg	lb	kg	deg	deg	lb	kg								
STD	118.1	3,000	78.7	2,000	159.4	4,050	141.9	3,605	5.1	130	5.1	130	5	7	4000	2,000	5	7	4000	2,000
	129.9	3,300	84.6	2,150	171.3	4,350	153.7	3,905	5.1	130	5.1	130	5	7	4000	2,000	5	7	4000	2,000
	137.8	3,500	88.6	2,250	179.1	4,550	161.6	4,105	5.1	130	5.1	130	5	7	4000	2,000	5	7	4000	2,000
	145.7	3,700	92.5	2,350	187.0	4,750	169.5	4,305	5.1	130	5.1	130	5	7	4000	2,000	5	7	4000	2,000
	157.5	4,000	100.4	2,550	198.8	5,050	181.3	4,605	5.1	130	5.1	130	5	7	4000	2,000	5	7	4000	2,000
	177.2	4,500	110.2	2,800	218.5	5,550	201.0	5,105	5.1	130	5.1	130	5	7	3900	1,950	5	7	4000	2,000
FF	106.3	2,700	72.8	1,850	147.6	3,750	131.1	3,330	33.3	845	49.8	1,265	5	5	4000	2,000	5	5	4000	2,000
	118.1	3,000	78.7	2,000	159.4	4,050	142.9	3,630	39.2	995	55.7	1,415	5	5	4000	2,000	5	5	4000	2,000
	129.9	3,300	84.6	2,150	171.3	4,350	154.7	3,930	45.1	1,145	61.6	1,565	5	5	4000	2,000	5	5	4000	2,000
FFT	157.5	4,000	74.0	1,880	199.0	5,055	182.5	4,635	34.4	875	51.0	1,295	5	5	3900	1,950	5	5	4000	2,000
	177.2	4,500	80.5	2,045	218.5	5,550	202.0	5,130	40.9	1,040	57.5	1,460	5	5	3750	1,875	5	5	3950	1,975
	187.0	4,750	83.9	2,130	228.3	5,800	211.8	5,380	44.3	1,125	60.8	1,545	5	5	3650	1,825	5	5	3850	1,925
	196.9	5,000	88.4	2,245	238.2	6,050	221.7	5,630	48.8	1,240	65.4	1,660	5	5	3600	1,800	5	5	3800	1,900
	216.5	5,500	97.6	2,480	258.1	6,555	241.5	6,135	58.1	1,475	74.6	1,895	5	5	3400	1,700	5	5	3600	1,800
	236.2	6,000	104.1	2,645	277.6	7,050	261.0	6,630	64.6	1,640	81.1	2,060	5	5	3150	1,575	5	5	3000	1,500

Nota: Estas capacidades de carga se basan en el chasis estándar sin cambiador lateral.

Los valores de especificación citados en este catálogo se han redondeado.

Los productos y especificaciones están sujetos a mejoras y cambios sin previo aviso.

El rendimiento puede variar debido a las condiciones de funcionamiento.

El rendimiento que se muestra representa los valores nominales obtenidos en condiciones de funcionamiento típicas.

B16X-7

Tipo Mst	Max. Altura horquilla		Altura completamente bajada		Altura Completamente Extendida				Elevación Libre				Capacidades de carga nominal											
					Con respaldo de carga		Sin respaldo de carga		Con respaldo de carga		Sin respaldo de carga		Llanta Solida Simple				Llanta Cushion Simple							
					Ángulo inclin.		Cap. Carga		Ángulo inclin.		Cap. Carga		FWD		BWD		LC 24" (500mm)		FWD		BWD		LC 24" (500mm)	
					deg	deg	lb	kg	deg	deg	lb	kg	deg	deg	deg	deg	deg	deg	deg	deg	deg	deg	deg	deg
STD	118.1	3,000	78.7	2,000	159.3	4,045	141.7	3,600	5.1	130	5.1	130	5	7	3200	1,600	5	7	3200	1,600				
	129.9	3,300	84.6	2,150	171.1	4,345	153.5	3,900	5.1	130	5.1	130	5	7	3200	1,600	5	7	3200	1,600				
	137.8	3,500	88.6	2,250	178.9	4,545	161.4	4,100	5.1	130	5.1	130	5	7	3200	1,600	5	7	3200	1,600				
	145.7	3,700	92.5	2,350	186.8	4,745	169.3	4,300	5.1	130	5.1	130	5	7	3200	1,600	5	7	3200	1,600				
	157.5	4,000	100.4	2,550	198.6	5,045	181.1	4,600	5.1	130	5.1	130	5	7	3200	1,600	5	7	3200	1,600				
177.2	4,500	110.2	2,800	218.3	5,545	200.8	5,100	5.1	130	5.1	130	5	7	3200	1,600	5	7	3200	1,600					
FF	106.3	2,700	72.8	1,850	147.4	3,745	130.9	3,325	33.3	845	49.8	1,265	5	5	3200	1,600	5	5	3200	1,600				
	118.1	3,000	78.7	2,000	159.3	4,045	142.7	3,625	39.2	995	55.7	1,415	5	5	3200	1,600	5	5	3200	1,600				
	129.9	3,300	84.6	2,150	171.1	4,345	154.5	3,925	45.1	1,145	61.6	1,565	5	5	3200	1,600	5	5	3200	1,600				
FFT	157.5	4,000	74.0	1,880	198.8	5,050	182.3	4,630	34.4	875	51.0	1,295	5	5	3200	1,600	5	5	3200	1,600				
	177.2	4,500	80.5	2,045	218.3	5,545	201.8	5,125	40.9	1,040	57.5	1,460	5	5	3100	1,550	5	5	3050	1,525				
	187.0	4,750	83.9	2,130	228.1	5,795	211.6	5,375	44.3	1,125	60.8	1,545	5	5	3000	1,500	5	5	2950	1,475				
	196.9	5,000	88.4	2,245	238.0	6,045	221.5	5,625	48.8	1,240	65.4	1,660	5	5	2900	1,450	5	5	2900	1,450				
	216.5	5,500	97.6	2,480	257.9	6,550	241.3	6,130	58.1	1,475	74.6	1,895	5	5	2700	1,350	5	5	2700	1,350				
	236.2	6,000	104.1	2,645	277.4	7,045	260.8	6,625	64.6	1,640	81.1	2,060	5	5	2500	1,250	5	5	2150	1,075				

B18X-7

Tipo Mst	Max. Altura horquilla		Altura completamente bajada		Altura Completamente Extendida				Elevación Libre				Capacidades de carga nominal											
					Con respaldo de carga		Sin respaldo de carga		Con respaldo de carga		Sin respaldo de carga		Llanta Solida Simple				Llanta Cushion Simple							
					Ángulo inclin.		Cap. Carga		Ángulo inclin.		Cap. Carga		FWD		BWD		LC 24" (500mm)		FWD		BWD		LC 24" (500mm)	
					deg	deg	lb	kg	deg	deg	lb	kg	deg	deg	deg	deg	deg	deg	deg	deg	deg	deg	deg	deg
STD	118.1	3,000	78.7	2,000	159.3	4,045	141.7	3,600	5.1	130	5.1	130	5	7	3600	1,800	n/a	n/a						
	129.9	3,300	84.6	2,150	171.1	4,345	153.5	3,900	5.1	130	5.1	130	5	7	3600	1,800								
	137.8	3,500	88.6	2,250	178.9	4,545	161.4	4,100	5.1	130	5.1	130	5	7	3600	1,800								
	145.7	3,700	92.5	2,350	186.8	4,745	169.3	4,300	5.1	130	5.1	130	5	7	3600	1,800								
	157.5	4,000	100.4	2,550	198.6	5,045	181.1	4,600	5.1	130	5.1	130	5	7	3600	1,800								
177.2	4,500	110.2	2,800	218.3	5,545	200.8	5,100	5.1	130	5.1	130	5	7	3400	1,700									
FF	106.3	2,700	72.8	1,850	147.4	3,745	130.9	3,325	33.3	845	49.8	1,265	5	5	3600	1,800	n/a	n/a						
	118.1	3,000	78.7	2,000	159.3	4,045	142.7	3,625	39.2	995	55.7	1,415	5	5	3600	1,800								
	129.9	3,300	84.6	2,150	171.1	4,345	154.5	3,925	45.1	1,145	61.6	1,565	5	5	3600	1,800								
FFT	157.5	4,000	74.0	1,880	198.8	5,050	182.3	4,630	34.4	875	51.0	1,295	5	5	3600	1,800	n/a	n/a						
	177.2	4,500	80.5	2,045	218.3	5,545	201.8	5,125	40.9	1,040	57.5	1,460	5	5	3500	1,750								
	187.0	4,750	83.9	2,130	228.1	5,795	211.6	5,375	44.3	1,125	60.8	1,545	5	5	3200	1,600								
	196.9	5,000	88.4	2,245	238.0	6,045	221.5	5,625	48.8	1,240	65.4	1,660	5	5	3100	1,550								
	216.5	5,500	97.6	2,480	257.9	6,550	241.3	6,130	58.1	1,475	74.6	1,895	5	5	2950	1,475								
	236.2	6,000	104.1	2,645	277.4	7,045	260.8	6,625	64.6	1,640	81.1	2,060	5	5	2700	1,350								

B20X-7

Tipo Mst	Max. Altura horquilla		Altura completamente bajada		Altura Completamente Extendida				Elevación Libre				Capacidades de carga nominal											
					Con respaldo de carga		Sin respaldo de carga		Con respaldo de carga		Sin respaldo de carga		Llanta Solida Simple				Llanta Cushion Simple							
					Ángulo inclin.		Cap. Carga		Ángulo inclin.		Cap. Carga		FWD		BWD		LC 24" (500mm)		FWD		BWD		LC 24" (500mm)	
					deg	deg	lb	kg	deg	deg	lb	kg	deg	deg	deg	deg	deg	deg	deg	deg	deg	deg	deg	deg
STD	118.1	3,000	78.7	2,000	159.4	4,050	141.9	3,605	5.1	130	5.1	130	5	7	4000	2,000	n/a	n/a						
	129.9	3,300	84.6	2,150	171.3	4,350	153.7	3,905	5.1	130	5.1	130	5	7	4000	2,000								
	137.8	3,500	88.6	2,250	179.1	4,550	161.6	4,105	5.1	130	5.1	130	5	7	4000	2,000								
	145.7	3,700	92.5	2,350	187.0	4,750	169.5	4,305	5.1	130	5.1	130	5	7	4000	2,000								
	157.5	4,000	100.4	2,550	198.8	5,050	181.3	4,605	5.1	130	5.1	130	5	7	4000	2,000								
177.2	4,500	110.2	2,800	218.5	5,550	201.0	5,105	5.1	130	5.1	130	5	7	3800	1,900									
FF	106.3	2,700	72.8	1,850	147.6	3,750	131.1	3,330	33.3	845	49.8	1,265	5	5	4000	2,000	n/a	n/a						
	118.1	3,000	78.7	2,000	159.4	4,050	142.9	3,630	39.2	995	55.7	1,415	5	5	4000	2,000								
	129.9	3,300	84.6	2,150	171.3	4,350	154.7	3,930	45.1	1,145	61.6	1,565	5	5	4000	2,000								
FFT	157.5	4,000	74.0	1,880	199.0	5,055	182.5	4,635	34.4	875	51.0	1,295	5	5	3800	1,900	n/a	n/a						
	177.2	4,500	80.5	2,045	218.5	5,550	202.0	5,130	40.9	1,040	57.5	1,460	5	5	3800	1,900								
	187.0	4,750	83.9	2,130	228.3	5,800	211.8	5,380	44.3	1,125	60.8	1,545	5	5	3600	1,800								
	196.9	5,000	88.4	2,245	238.2	6,050	221.7	5,630	48.8	1,240	65.4	1,660	5	5	3450	1,725								
	216.5	5,500	97.6	2,480	258.1	6,555	241.5	6,135	58.1	1,475	74.6	1,895	5	5	3300	1,650								
	236.2	6,000	104.1	2,645	277.6	7,050	261.0	6,630	64.6	1,640	81.1	2,060	5	5	3000	1,500								

Nota: Estas capacidades de carga se basan en el chasis estándar sin cambiador lateral.

Especificaciones generales - 48V

Características	1	Modelo		B16X-7	B18X-7	B20X-7			
	2	Capacidad de carga	en el centro de carga nominal	lb(kg)	3200 (1600)	3600 (1800)	4000 (2000)		
	3	Centro de carga		in(mm)	24 (500)	24 (500)	24 (500)		
	4	Tipo de potencia			Eléctrico AC	Eléctrico AC	Eléctrico AC		
	5	Tipo de operador			Sentado	Sentado	Sentado		
	6	Tipo de llanta	P=neumático, E=sólido, C=cushion		SE / P*	SE	SE		
	7	Llantas (x=impulso)	número: adelante/detrás		x 2/2	x 2/2	x 2/2		
Dimensiones	8	Max. Altura Horquilla	con mástil STD de 2 etapas	in(mm)	130 (3300)	130 (3300)	130 (3300)		
	9	Elevación libre		in(mm)	5.1 (130)	5.1 (130)	5.3 (135)		
	10	Carro de horquillas			II	II	II		
	11	Horquillas	espesor x ancho x alto		in(mm)	1.4 / 3.9 / 41.3 (35 / 100 / 900)	1.4 / 3.9 / 41.3 (35 / 100 / 900)	1.6 / 3.9 / 41.3 (40 / 100 / 900)	
			espacio entre horquillas (min x max)		in(mm)	9.5 / 35.6 (240 / 905)	9.5 / 35.6 (240 / 905)	9.5 / 35.6 (240 / 905)	
	12	Inclinación del mástil	adelante/atrás	deg	5/7	5/7	5/7		
	13-19	Dimensiones totales	longitud hasta la cara de la horquilla		in(mm)	83.4 (2120)	83.4 (2120)	83.6 (2125)	
			longitud total		in(mm)	124.7 (3020)	124.7 (3020)	124.9 (3025)	
			ancho promedio		in(mm)	42.9 (1090)	44.1 (1119)	44.1 (1119)	
			altura bajada del mástil		in(mm)	84.6 (2150)	84.6 (2150)	84.6 (2150)	
			altura extendida del mástil		in(mm)	171 (4345)	171 (4345)	171.3 (4350)	
			altura del techo protector		in(mm)	79 (2010)	79 (2010)	79 (2010)	
	18	altura del asiento		in(mm)	36.2 (919)	36.2 (919)	36.2 (919)		
	20	Radio de giro exterior		in(mm)	74.2 (1886)	74.2 (1886)	74.2 (1886)		
	21	Radio de giro interior		in(mm)	19.4 (494)	19.4 (494)	19.4 (494)		
	22	Centro del momento de carga	centro del eje a cara de horquilla		in(mm)	14.8 (376)	14.8 (376)	15.0 (381)	
	23	Ancho del pasillo de apilamiento en ángulo recto (con paletas y espacio libre)	Tarima de 48 "x 40" (1000 x 1200)		in(mm)	136.4 (3466)	136.4 (3466)	136.6 (3471)	
Tarima de 48 "x 31" (800 x 1200)			in(mm)	144.3 (3665)	144.3 (3665)	144.5 (3670)			
Performance	25-27	Velocidad	desplazamiento	cargado/descargado	mph(km/h)	10.6 / 10.6 (17 / 17)	10.6 / 10.6 (17 / 17)	10.6 / 10.6 (17 / 17)	
			levantamiento	cargado/descargado	fpm(mm/s)	79 / 118 (400 / 600)	79 / 118 (400 / 600)	79 / 118 (400 / 600)	
			bajada	cargado/descargado	fpm(mm/s)	98/89 (500/450)	98/89 (500/450)	98/89 (500/450)	
	28	Tracción max. barra de tiro	cargada a 1.0 mph		lb(kg)	2864 (1300)	2864 (1300)	2864 (1300)	
29	Cap. max. subida pendientes	cargada a 1.0 mph		%	26	25	24		
Peso	30	Peso total		con el peso mínimo de la batería	lb(kg)	6858 (3111)	7233 (3281)	7630 (3461)	
	31-32	Carga por eje	cargado, delantero / trasero		lb(kg)	9341 / 1045 (4237 / 474)	10033 / 1168 (4551 / 530)	10738 / 1301 (4871 / 590)	
			descargado, delantero / trasero		lb(kg)	3748 / 3111 (1700 / 1411)	3739 / 3494 (1696 / 1585)	3730 / 3900 (1692 / 1769)	
Chasis	33-34	Llantas	tamaño	delantero		18x7-8 (a)	200x50-10	200x50-10	
				trasero		16x6-8 (b)	16x6-8	16x6-8	
	35	Distancia entre ejes	distancia		in(mm)	58.8 (1495)	58.8 (1495)	58.8 (1495)	
	36-37	Ancho de la banda de rodadura	delantero		in(mm)	35.5 (902)	35.9 (912)	35.9 (912)	
			trasero		in(mm)	35 (890)	35 (890)	35 (890)	
	38-39	Distancia al suelo	cargado	la más baja	in(mm)	3.4 (86)	3.4 (86)	3.4 (86)	
				en el centro de los ejes	in(mm)	3.9 (100)	3.9 (100)	3.9 (100)	
40	Frenos	Servicio			Hidráulico	Hidráulico	Hidráulico		
		Estacionamiento			Autoeléctrico	Autoeléctrico	Autoeléctrico		
Tren de Potencia	41	Batería	tipo			plomo-ácido	plomo-ácido	plomo-ácido	
			voltaje		V	48	48	48	
			capacidad (calificación 5 horas)	nominal	tipo BS	AH	585	585	585
					tipo DIN	AH	575	575	575
				max.	tipo BS	AH	690	690	690
					tipo DIN	AH	625	625	625
			tamaño del compartimento de la batería (ancho x largo x alto) máx.		normal	in(mm)	25.1 x 39.1 x 27.5 (638 x 992 x 698)	25.1 x 39.1 x 27.5 (638 x 992 x 698)	25.1 x 39.1 x 27.5 (638 x 992 x 698)
				tipo BS	in(mm)	25.1 (23.9) x 39.1 x 27.5 (638 (608) x 992 x 698)**	25.1 (23.9) x 39.1 x 27.5 (638 (608) x 992 x 698)**	25.1 (23.9) x 39.1 x 27.5 (638 (608) x 992 x 698)**	
				tipo DIN	in(mm)	25.1 x 39.1 (33.1) x 27.5 (638 x 992 (842) x 698)***	25.1 x 39.1 (33.1) x 27.5 (638 x 992 (842) x 698)***	25.1 x 39.1 (33.1) x 27.5 (638 x 992 (842) x 698)***	
			peso (min/max)		lb(kg)	2315 / 2755 (1050 / 1250)	2315 / 2755 (1050 / 1250)	2315 / 2755 (1050 / 1250)	
			42	Motor eléctrico	motor de accionamiento en S2 60 min.		kW	6.0 x 2	6.0 x 2
motor de elevación en S3 15%		kW			14	14	14		
43	Tipo de control	accionamiento e hidráulico			AC	AC	AC		
44	Eje motriz	tipo de freno			ODB	ODB	ODB		
45-46	Presión de alivio	sistema		psi (kPa)	2880 (19860)	2880 (19860)	3125 (21550)		
		ajunto		psi (kPa)	2040 (14000)	2040 (14000)	2040 (14000)		
47	Depósito de aceite hidráulico	capacidad		L	20	20	20		

* Opcional (a) Neumáticos 18 x 7-8 ** Si el operador utiliza una batería tipo BS (608 mm de longitud / 575,630 690 / 5h de capacidad), se debe elegir un accesorio especial (tapón).

(b) Neumáticos 16 x 6-8 *** Si el operador utiliza una batería tipo DIN (842 mm de ancho), se debe elegir un accesorio especial (soporte).

1	B15T-7	B18T-7	B18TL-7	B20T-7	B20TL-7
2	3000 (1500)	3500 (1750)	3500 (1750)	4000 (2000)	4000 (2000)
3	24 (500)	24 (500)	24 (500)	24 (500)	24 (500)
4	Eléctrico AC	Eléctrico AC	Eléctrico AC	Eléctrico AC	Eléctrico AC
5	Sentado	Sentado	Sentado	Sentado	Sentado
6	SE / C*	SE / C*	SE / C*	SE / C*	SE / C*
7	x 2 / 1	x 2 / 1	x 2 / 1	x 2 / 1	x 2 / 1
8	130 (3300)	130 (3300)	130 (3300)	130 (3300)	130 (3300)
9	5.1 (130)	5.1 (130)	5.1 (130)	5.3 (135)	5.3 (135)
10	II	II	II	II	II
11	1.4 / 3.9 / 41.3 (35 / 100 / 900)	1.4 / 3.9 / 41.3 (35 / 100 / 900)	1.4 / 3.9 / 41.3 (35 / 100 / 900)	1.6 / 3.9 / 41.3 (40 / 100 / 900)	1.6 / 3.9 / 41.3 (40 / 100 / 900)
	9.5 / 35.6 (240 / 905)	9.5 / 35.6 (240 / 905)	9.5 / 35.6 (240 / 905)	9.5 / 35.6 (240 / 905)	9.5 / 35.6 (240 / 905)
12	5/7	5/7	5/7	5/7	5/7
13	74.4 (1891)	78.4 (1991)	83.9 (2132)	79.9 (2029)	84.1 (2137)
14	115.7 (2791)	119.7 (2891)	125.2 (3032)	121.2 (2929)	125.4 (3037)
15	42.9 (1090)	42.9 (1090)	42.9 (1090)	44.1 (1119)	44.1 (1119)
16	84.6 (2150)	84.6 (2150)	84.6 (2150)	84.6 (2150)	84.6 (2150)
17	171 (4345)	171 (4345)	171 (4345)	171.3 (4350)	171.3 (4350)
18	79 (2010)	79 (2010)	79 (2010)	79 (2010)	79 (2010)
19	36.2 (919)	36.2 (919)	36.2 (919)	36.2 (919)	36.2 (919)
20	59.6 (1515)	63.6 (1615)	69.1 (1756)	64.9 (1648)	69.1 (1756)
21	-	-	-	-	-
22	14.8 (376)	14.8 (376)	14.8 (376)	15.0 (381)	15.0 (381)
23	126.6 (3216)	130.5 (3316)	136.1 (3457)	132 (3354)	136.3 (3462)
24	131.5 (3341)	135.5 (3441)	141.0 (3582)	137 (3479)	141.2 (3587)
25	10.6 / 10.6 (17 / 17)	10.6 / 10.6 (17 / 17)	10.6 / 10.6 (17 / 17)	10.6 / 10.6 (17 / 17)	10.6 / 10.6 (17 / 17)
26	79 / 118 (400 / 600)	79 / 118 (400 / 600)	79 / 118 (400 / 600)	79 / 118 (400 / 600)	79 / 118 (400 / 600)
27	98/89 (500/450)	98/89 (500/450)	98/89 (500/450)	98/89 (500/450)	98/89 (500/450)
28	2864 (1300)	2864 (1300)	2864 (1300)	2864 (1300)	2864 (1300)
29	26	25	25	24	24
30	6675 (3028)	6927 (3142)	7348 (3333)	7654 (3472)	7348 (3333)
31	8792 / 1190 (3988 / 540)	9607 / 1177 (4358 / 534)	9638 / 1569 (4372 / 712)	10672 / 1391 (4841 / 631)	10513 / 1243 (4769 / 564)
32	3296 / 3379 (1495 / 1533)	3373 / 3553 (1530 / 1612)	3604 / 3743 (1635 / 1698)	3578 / 4076 (1623 / 1849)	3604 / 3743 (1635 / 1698)
33	18x7-8 (c)	18x7-8 (c)	18x7-8 (c)	200x50-10 (c)	200x50-10 (c)
34	15x4.5-8 (d)	15x4.5-8 (d)	15x4.5-8 (d)	16x6-8 (d)	16x6-8 (d)
35	52 (1323)	56 (1423)	61.2 (1554)	57 (1446)	61.2 (1554)
36	35.5 (902)	35.5 (902)	35.5 (902)	35.9 (912)	35.9 (912)
37	6.6 (167)	6.6 (167)	6.6 (167)	7.9 (201)	7.9 (201)
38	3.4 (86)	3.4 (86)	3.4 (86)	3.4 (86)	3.4 (86)
39	3.9 (100)	3.9 (100)	3.9 (100)	3.9 (100)	3.9 (100)
40	Hidráulico	Hidráulico	Hidráulico	Hidráulico	Hidráulico
	Autoeléctrico plomo-ácido	Autoeléctrico plomo-ácido	Autoeléctrico plomo-ácido	Autoeléctrico plomo-ácido	Autoeléctrico plomo-ácido
41	48	48	48	48	48
	440	510	600	585	600
	460	525	690	575	690
	575	690	-	690	-
	500	625	750	625	750
	20.8 x 39.1 x 27.5 (528 x 992 x 698)	25.1 x 39.1 x 27.5 (638 x 992 x 698)	29.4 x 39.1 x 27.5 (746 x 992 x 698)	25.1 x 39.1 x 27.5 (638 x 992 x 698)	29.4 x 39.1 x 27.5 (746 x 992 x 698)
20.8 x 39.1 x 27.5 (528 x 992 x 698)	25.1 (23.9) x 39.1 x 27.5 (638 (608) x 992 x 698) (c)	-	25.1 (23.9) x 39.1 x 27.5 (638 (608) x 992 x 698) (c)	-	
20.8 x 39.1 (33.1) x 27.5 (528 x 992 (842) x 698) (d)	25.1 x 39.1 (33.1) x 27.5 (638 x 992 (842) x 698) (d)	29.4 x 39.1 (33.1) x 27.5 (746 x 992 (842) x 698) (d)	25.1 x 39.1 (33.1) x 27.5 (638 x 992 (842) x 698) (d)	29.4 x 39.1 (33.1) x 27.5 (746 x 992 (842) x 698) (d)	
1543 / 1836 (700 / 833)	1764 / 2330 (800 / 1057)	2205 / 2330 (1000 / 1057)	2205 / 2755 (1000 / 1250)	2205 / 2755 (1000 / 1250)	
42	6.0 x 2	6.0 x 2	6.0 x 2	6.0 x 2	6.0 x 2
43	14	14	14	14	14
44	AC	AC	AC	AC	AC
45	ODB	ODB	ODB	ODB	ODB
46	2550 (17600)	2880 (19860)	2880 (19860)	3125 (21550)	3125 (21550)
47	2040 (14000)	2040 (14000)	2040 (14000)	2040 (14000)	2040 (14000)
48	20	20	20	20	20

* Opcional (c) Llantas cushion 18 x 7-12.12

(d) Llantas cushion 15 x 6-11.25

Especificaciones generales - 36V

Características	1	Modelo			B15T-7	B18T-7	B20T-7		
	2	Capacidad de carga	en el centro de carga nominal	lb(kg)	3000 (1500)	3500 (1750)	4000 (2000)		
	3	Centro de carga		in(mm)	24 (500)	24 (500)	24 (500)		
	4	Tipo de potencia			Eléctrico AC	Eléctrico AC	Eléctrico AC		
	5	Tipo de operador			Sentado	Sentado	Sentado		
	6	Tipo de llanta	P=neumático, E=sólido, C=cushion		C / SE*	C / SE*	C / SE*		
	7	Llantas (x=impulso)	numéro: adelante/detrás		x 2 / 1	x 2 / 1	x 2 / 1		
Dimensiones	8	Max. Altura Horquilla	con mástil STD de 2 etapas	in(mm)	130 (3300)	130 (3300)	130 (3300)		
	9	Elevación libre		in(mm)	5.1 (130)	5.1 (130)	5.3 (135)		
	10	Carro de horquillas			II	II	II		
	11	Horquillas	espesor x ancho x alto	in(mm)	1.4 / 3.9 / 41.3 (35 / 100 / 900)	1.4 / 3.9 / 41.3 (35 / 100 / 900)	1.6 / 3.9 / 41.3 (40 / 100 / 900)		
			espacio entre horquillas (min x max)	in(mm)	9.5 / 35.6 (240 / 905)	9.5 / 35.6 (240 / 905)	9.5 / 35.6 (240 / 905)		
	12	Inclinación del mástil	adelante/detrás	deg	5/7	5/7	5/7		
	13-19	Dimensiones totales	longitud hasta la cara de la horquilla	in(mm)	74.4 (1891)	78.4 (1991)	79.9 (2029)		
			longitud total	in(mm)	115.7 (2791)	119.7 (2891)	121.2 (2929)		
			ancho promedio	in(mm)	42.9 (1090)	42.9 (1090)	42.9 (1090)		
			altura bajada del mástil	in(mm)	78.7 (2000)	78.7 (2000)	78.7 (2000)		
			altura extendida del mástil	in(mm)	159.3 (4045)	159.3 (4045)	159.4 (4050)		
			altura del techo protector	in(mm)	79 (2010)	79 (2010)	79 (2010)		
			altura del asiento	in(mm)	36.2 (919)	36.2 (919)	36.2 (919)		
	20	Radio de giro exterior		in(mm)	59.6 (1515)	63.6 (1615)	64.9 (1648)		
	21	Radio de giro interior		in(mm)	-	-	-		
	22	Centro del momento de carga	centro del eje a cara de horquilla	in(mm)	14.8 (376)	14.8 (376)	15.0 (381)		
	23	Ancho del pasillo de apilamiento en ángulo recto (con paletas y espacio libre)	Tarima de 48 "x 40" (1000 x 1200)	in(mm)	126.6 (3216)	130.5 (3316)	132 (3354)		
Tarima de 48 "x 31" (800 x 1200)			in(mm)	131.5 (3341)	135.5 (3441)	137 (3479)			
Performance	25-27	Velocidad	desplazamiento	cargado/descargado	mph(km/h)	8.7/8.7 (14.0/14.0)	8.7/8.7 (14.0/14.0)	8.7/8.7 (14.0/14.0)	
			levantamiento	cargado/descargado	fpm(mm/s)	61/108 (310/550)	61/108 (310/550)	61/108 (310/550)	
			bajada	cargado/descargado	fpm(mm/s)	98/89 (500/450)	98/89 (500/450)	98/89 (500/450)	
	28	Tracción max. barra de tiro	cargada a 1.0 mph	lb(kg)	2734 (1240)	2734 (1240)	2734 (1240)		
	29	Cap. max. subida pendientes	cargada a 1.0 mph	%	24	23	22		
Peso	30	Peso total	con el peso mínimo de la batería	lb(kg)	6821 (3094)	7072 (3208)	7910 (3588)		
	31-32	Carga por eje	cargado, delantero / trasero	lb(kg)	8858 / 1269 (4018 / 576)	9673 / 1256 (4388 / 570)	10785 / 1534 (4892 / 696)		
			descargado, delantero / trasero	lb(kg)	3362 / 3459 (1525 / 1569)	3439 / 3633 (1560 / 1648)	3688 / 4221 (1673 / 1915)		
Chasis	33-34	Llantas	tamaño	delantero		18x7x12.12	18x7x12.12	18x7x12.12	
			trasero		15x6x11.25	15x6x11.25	15x6x11.25		
	35	Distancia entre ejes	distancia	in(mm)	52 (1323)	56 (1423)	57 (1446)		
	36-37	Ancho de la banda de rodadura	delantero	in(mm)	35.5 (902)	35.5 (902)	35.5 (902)		
			trasero	in(mm)	7.8 (198)	7.8 (198)	7.8 (198)		
	38-39	Distancia al suelo	cargado	la más baja	in(mm)	3.4 (86)	3.4 (86)	3.4 (86)	
			en el centro de los ejes	in(mm)	3.9 (100)	3.9 (100)	3.9 (100)		
40	Frenos	Servicio		Hidráulico	Hidráulico	Hidráulico			
		Estacionamiento		Autoeléctrico	Autoeléctrico	Autoeléctrico			
Trend de Potencia	41	Batería	tipo			plomo-ácido	plomo-ácido	plomo-ácido	
			voltaje	V	36	36	36		
			capacidad (calificación 5 horas)	nominal	tipo BS	AH	660	825	825
				max.	tipo BS	AH	770	970	970
			tamaño del compartimento de la batería (ancho x largo x alto) máx.	normal	in(mm)	20.8 x 39.1 x 27.5 (528 x 992 x 698)	25.1 x 39.1 x 27.5 (638 x 992 x 698)	25.1 x 39.1 x 27.5 (638 x 992 x 698)	
				tipo BS	in(mm)	20.8 x 39.1 x 27.5 (528 x 992 x 698)	25.1 x 39.1 x 27.5 (638 x 992 x 698)	25.1 x 39.1 x 27.5 (638 x 992 x 698)	
			peso (min/max)	lb(kg)	1543 / 2083 (700 / 945)	1764 / 2645 (800 / 1200)	2315 / 2645 (1050 / 1200)		
	42	Motor eléctrico	motor de accionamiento en S2 60 min.	kW	6.0 x 2	6.0 x 2	6.0 x 2		
			motor de elevación en S3 15%	kW	14	14	14		
	43	Tipo de control	accionamiento e hidráulico	type	AC	AC	AC		
	44	Eje motriz	tipo de freno	type	ODB	ODB	ODB		
45-46	Presión de alivio	sistema	psi (kPa)	2550 (17600)	2880 (19860)	3125 (21550)			
		ajunto	psi (kPa)	2040 (14000)	2040 (14000)	2040 (14000)			
47	Depósito de aceite hidráulico	capacidad	L	20	20	20			

* Opcional (a) Llantas superelásticas 18 x 7-8
(a) Llantas superelásticas 15 x 4.5-8

(c) Llantas superelásticas 200 x 50-10
(d) Llantas superelásticas 16 x 6-8

Dibujo dimensional - 3 llantas

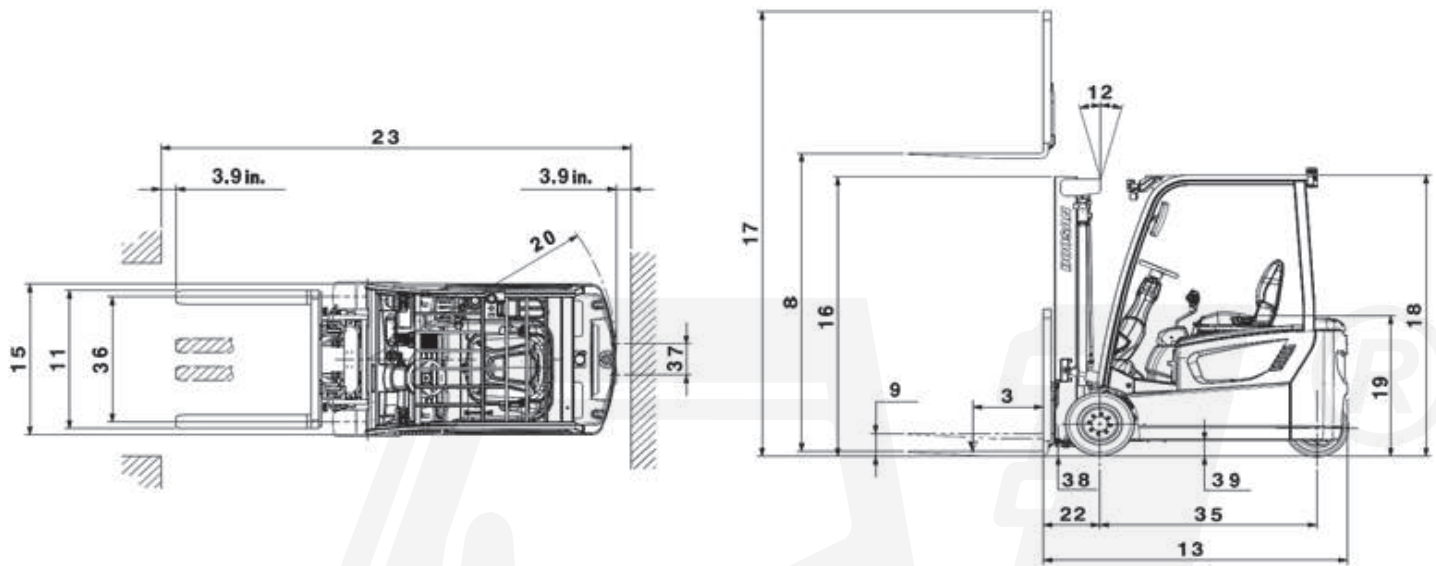

Dibujo dimensional - 4 llantas

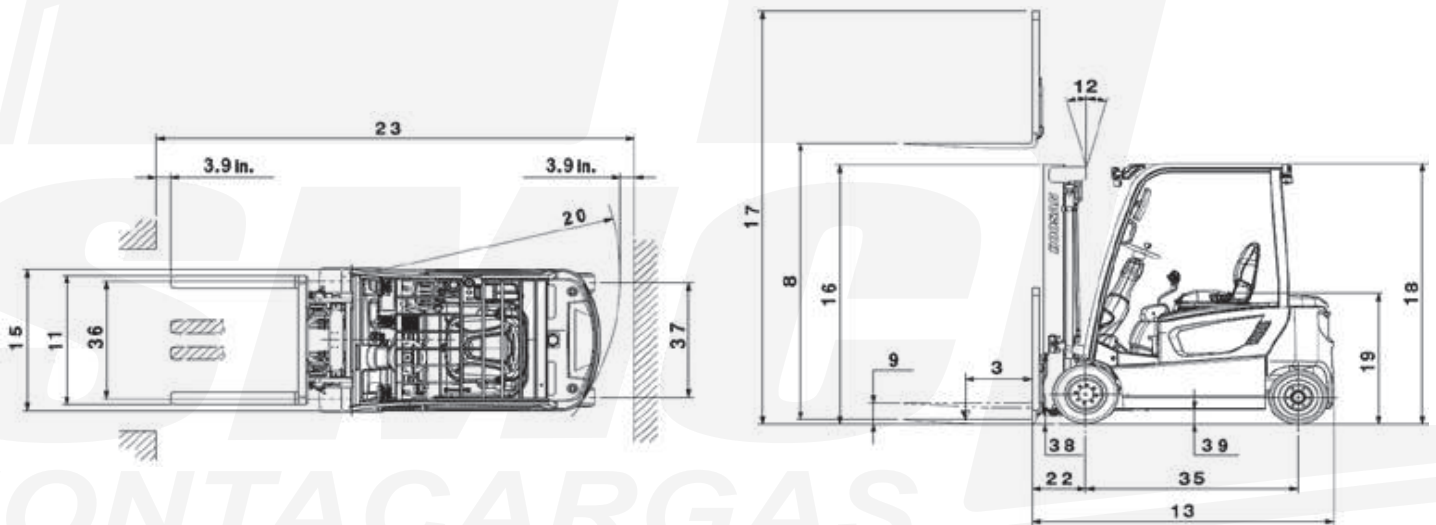

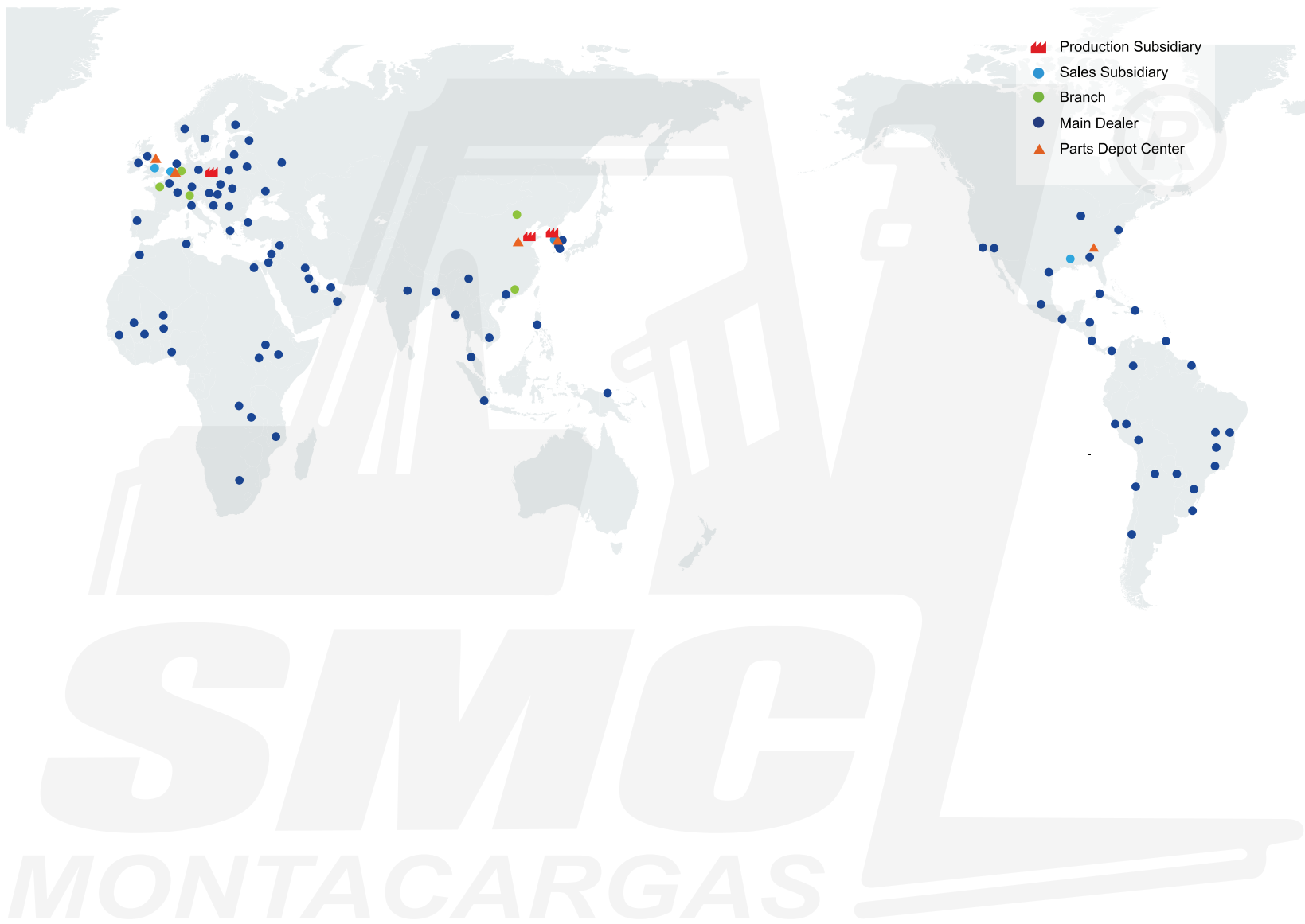

PSCG25N7-V1

AUTHORIZED DEALER

Atenco # 21, Col. Industrial La Perla, Naucalpan,
 Estado de México, México. CP 53340
 Tel. (55) 5371 3300
www.smcex.com.mx

